

Constant Pressure Water Systems

New technology eliminates water system pressure and flow fluctuations, resulting in consistent water delivery for better plant growth.

► Think your current pressure booster system is delivering as promised?

Think again. Standard pressure booster systems with on/off cycling pumps and pre-charged tanks provide a pressure range that typically fluctuates by 10-30 psi. Uneven irrigation loads and competing watering needs often amplify these pressure swings, further compromising the system. It's a problem that can have a direct impact on your bottom line.

► **Constant water pressure is key to quality irrigation.** No matter how large or small your greenhouse or nursery, constant water pressure throughout the operation is key to quality irrigation, which in turn affects plant growth. When pressure fluctuates, air gets into the lines, affecting boiler and boom performance. A water system that loses pressure by 50% will result in a lower nozzle output of about 30%, reducing water delivery and increasing labor.



About Delta T Constant Pressure Systems (CPS)

- Use a Variable Frequency Drive (VFD) to operate the pump and keep pressure within close tolerance, ranging from zero to full capacity flow.
- Arrive fully engineered to the flow rate and pressure you specify.
- Pre-plumbed, pre-wired, and mounted on a skid, system installation is quick and easy.
- Utilize any source of water, including ponds, atmospheric tanks, city water supplies, and well storage tanks.
- Cost no more than much less efficient pump and pre-charged tank systems.

How the Delta T CPS Works

- 1 A pressure sensor is placed in the pipe behind the pump. This provides feedback to a VFD.
- 2 The Variable Frequency Drive – a solid state controller – converts the pressure signal into a variable frequency three-phase output to the pump.
- 3 The pump receives the output and responds. If the water demand is low, the pump will turn just fast enough to either maintain pressure or shut down completely. If the demand is high, the pump will speed up to maintain pressure. There is no need to stage pumps.
- 4 Once set, no further supervision or adjustments are needed. Maintenance is limited to normal pump maintenance.

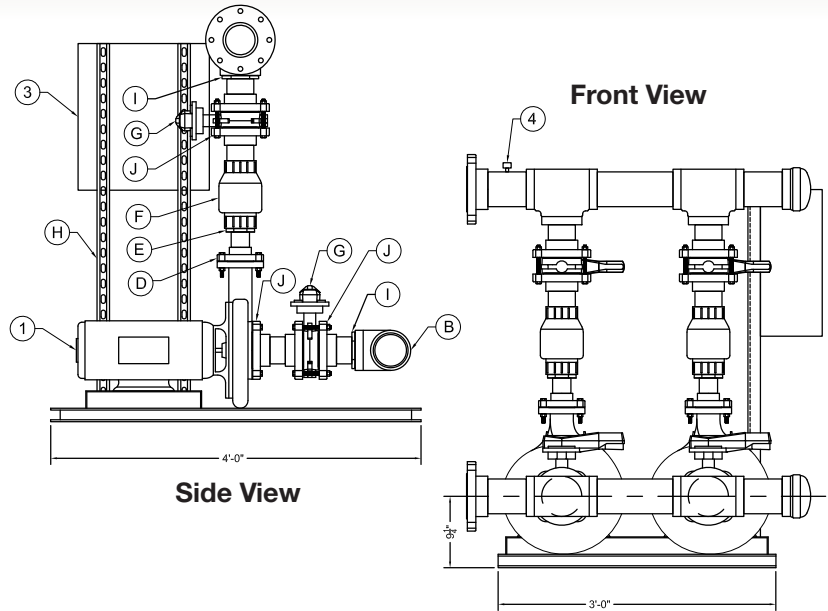

Specifications and Options

Desired System Pressure: Typically 70 psi

Maximum Flow Rate: Typically between 10 and 1000 gallons per minute. Technically, there is no limit to a system's flow rate. Accommodate future expansions by adding capacity to the original system, or installing additional pumps in parallel to the original.

Supply Voltage and Phases: Single or three-phase.

Redundancy: Although pumps and VFDs rarely break down, our CPS can be engineered with more than one pump in parallel. Then, should a breakdown occur, the system can continue to operate in some capacity, depending on the degree of redundancy built in.

Special Applications: Constant Pressure Systems can easily become Constant Flow Systems instead, which are particularly useful for flood bench or floor irrigation where all stations need to fill at the same time and speed, regardless of location.

Custom Configuration: If space constraints or other needs preclude the use of our normal skid configuration, then pumps, VFDs and other components can be supplied to the customer for installation. Contact a Delta T Solutions representative to learn more about establishing a customized system.

